

EXPORT MODEL  
**MHN33PN**  
 ENERGY ADVANTAGE™  
 FRONT-LOAD WASHER



### ADVANCED SPIN TECHNOLOGY

- Delivers more accurate cycle times and better unbalanced performance\*.
- A six-point suspension features four dampers and two springs, providing better stability for the entire wash unit.
- An accelerometer provides an accurate reading of cabinet vibration.



### DURACORE DRIVE SYSTEM

- Advanced drive system is more reliable.\*\*
- Watertight, flexible triple-lip seal with garter spring keeps moisture away from the shaft, protecting the premium bearings.
- Durable shaft sleeve is designed to eliminate shaft wear.



### MICROPROCESSOR CONTROLS

- Delivers powerful profits for owners and provides flexibility to customers. Controls offer owners the ability to customize vend prices and washer cycle options, such as Super Cycle, ensuring optional revenue. Controls also give customers the option to select the ideal cycle for individual wash needs.



### ENERGY-EFFICIENT CLEANING

- Uses on average 10.71 gallons of water per cycle, which helps reduce energy and water costs.
- TurboWash™ System's proven high-efficiency technology delivers energy savings without sacrificing cleaning performance.

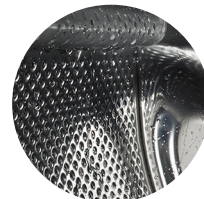

### MAYTAG CONNECT 360°™ COMPATIBLE

- Delivers real-time machine diagnostics to any tablet, computer or smartphone via the cloud. Management and feedback features offer owners the ultimate in machine control keeping you informed regarding pricing, service and diagnosis from anywhere you have access to the Internet.



\*Compared to previous model, MHN30, based on 18-lb load.  
 \*\*Compared to previous model, MHN30.



REDESIGNED BELLOW



ROBUST HINGE



DURABLE DISPENSER



FRONT ACCESS PANEL



Visit [maytagcommerciallaundry.com](http://maytagcommerciallaundry.com) or call 800-662-3587

MY160019

## OUR COMMITMENT TO DEPENDABLE QUALITY

For well over 50 years, Maytag® Commercial Laundry has promised and delivered dependability. We create that quality by making durable washers and dryers, built to endure heavy use and last for years. We design our machines to perform reliably and to produce consistent results. Finally, we give our washers and dryers the power to do their jobs thoroughly, cleaning and drying laundry quickly and efficiently—and justifying the trust that has been placed in us for generations.

## MAYTAG® ENERGY ADVANTAGE™ HE FRONT-LOAD WASHER MICROPROCESSOR CONTROLS, CARD READER-READY OR NON-COIN OPERATION

WASHER SPECIFICATIONS	
EXPORT MODEL	MHN33PN
<b>MOTOR</b>	
Variable-speed, reversible, thermoprotected, high-efficiency, controlled induction	Yes
Wash—HP (kw)	.09 (.07)
Extract—HP (kw)	.54 (.40)
Average energy consumption per cycle (kWh)	.054
<b>CAPACITY</b>	
Cylinder volume—cu. ft. (liters)	3.1 (88)
Cylinder diameter—in. (mm)	21.6 (547)
Cylinder depth—in. (mm)	13.4 (341)
<b>WATER INLET HOSE</b>	
Ft. (m)	4 (1.22)
<b>DRAIN HOSE</b>	
Ft. (m)	6 (1.83)
<b>APPROXIMATE WATER USAGE—GALLONS (LITERS)</b>	
Average hot water usage, hot water cycle	2.71 (10.26)
Average hot water usage, warm water cycle	.71 (2.69)
Average total water usage per cycle	10.71 (40.5)*
Modified Energy Factor (MEF)	2.45
Water Factor (WF)	3.50
<b>ELECTRICAL RATING</b>	
Export model—voltage	220–240V/50Hz
<b>BREAKER/FUSE MIN. REQUIREMENTS</b>	
Export model—amps	10
<b>WASH SPEED—RPM</b>	
	40
<b>EXTRACT SPEED—MAX RPM/MAX G-FORCE</b>	
	1,000/300
<b>WATER SUPPLY PRESSURE</b>	
Psi (bar)	20–100 (1–8)
<b>SOUND LEVEL (export model only)</b>	
Sound pressure level, Lpa (dbA) (Kpa: ± 3.6 dbA)	58
<b>ADJUSTABLE LEVELING LEGS</b>	
	Yes
<b>COLOR</b>	
	White
<b>APPROXIMATE WEIGHT</b>	
Crated—lbs. (kg)	244 (111)
Uncrated—lbs. (kg)	235 (107)
<b>DIMENSIONS</b>	
Width—in. (mm)	27 (686)
Depth—in. (mm) includes handle	28.81 (732)
Height—in. (mm)	37.81 (961)
Door opening diameter—in. (mm)	14.25 (362)
<b>OPTIONAL PEDESTAL ADD:</b>	
Height—in. (mm)	2.75 (70)

\*Average based on DOE J1 testing with factory preset cycles.  
Dimensions are for planning purposes only. See specific instructions for proper installation. Because of continuous product improvement, Maytag reserves the right to change specifications without notice.

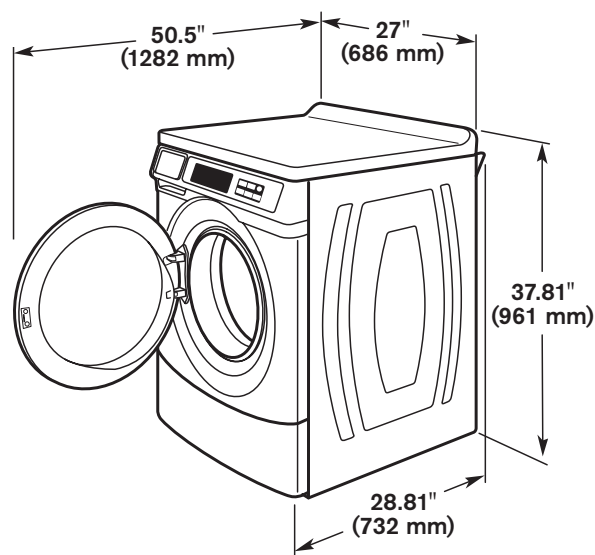

### 5-YEAR LIMITED WARRANTY ALL PARTS COVERED

For a period from the date of original purchase through the time listed above, the designated parts that fail in normal commercial use will be repaired or replaced free of charge for the part itself, with the owner paying all other costs, including labor, transportation and customs duty. Chemical damage is excluded from all warranty coverage. See complete warranty for details.