

# MAYTAG® COMMERCIAL LAUNDRY INDUSTRIAL WASHERS

Dependable engineering to tackle even the most demanding applications.



WHAT'S INSIDE MATTERS™

## DIMENSIONS AND TECHNICAL SPECIFICATIONS

(Models MFS230 and MFS275 with Tilting Feature)

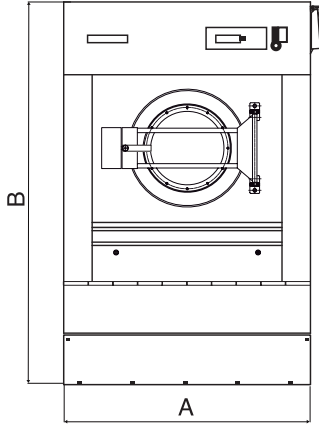

Front View

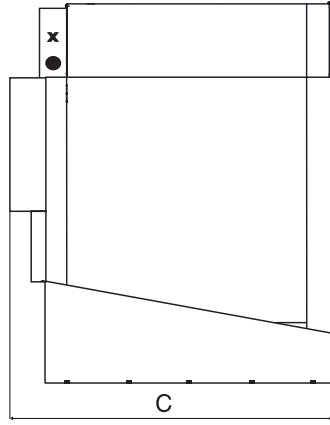

Side View

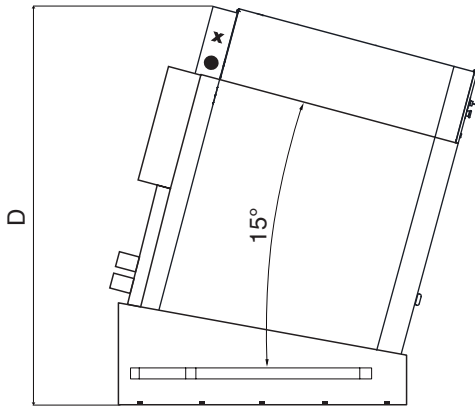

Side View

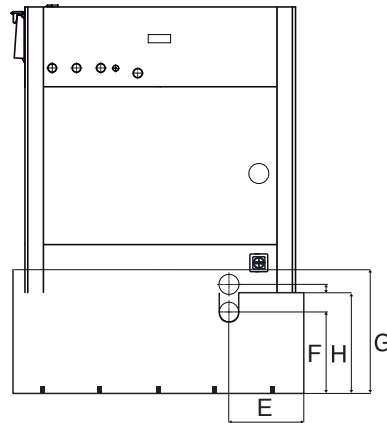

Rear View

## DIMENSIONS AND CONNECTIONS

WASHER CAPACITY	230 lbs (104 kg)	275 lbs (125 kg)
A	73.22" (1,860 mm)	73.22" (1,860 mm)
B	86.38" (2,194 mm)	91.54" (2,325 mm)
C	83.07" (2,110 mm)	85.51" (2,172 mm)
D	97.32" (2,472 mm)	103.27" (2,623 mm)
E	24.80" (630 mm)	24.02" (610 mm)
F	19.37" (492 mm)	19.61" (498 mm)
G	27.36" (695 mm)	26.97" (685 mm)
H	25.28" (642 mm)	25.51" (648 mm)

# MAYTAG® COMMERCIAL ENERGY ADVANTAGE™ SOFT-MOUNT INDUSTRIAL WASHER/EXTRACTORS

## DEPENDABLE MEETS INDUSTRIAL

With an unmatched reputation for performance you can count on, **Maytag is America's #1 preferred Laundry Brand**. And with our industrial line of washer/extractors, we're bringing dependability and efficiency to help industrial launderers meet even the most demanding applications.

Our sophisticated, yet simple-to-use industrial products are designed to help you complete even the most demanding laundry tasks with ease. You'll have more control at your fingertips, in addition to the ability to be faster and more accurate. And on top of it all, you'll have the confidence of knowing your Maytag® washer/extractor will continue to exceed your expectations—both today and in the future.



## FULLY PROGRAMMABLE CONTROLS

- Microprocessor controls offer 15 pre-programmed cycles and 30 industry-specific cycles, plus the ability to program multiple unique cycles—allowing users to control every phase of the wash process.
- Simple setup, one-touch cycle selection, a graphic display, and multilingual readouts make the controls easy for everyone to operate.
- With optional software, our fully programmable controls offer the technology to remotely create, copy and edit programs; monitor wash temperatures, water levels, cycle times and spin speeds; receive diagnostics; and generate reports.

## FAST, SIMPLE, AND PRECISE CHEMICAL INJECTION

- Eliminates the need to add detergent manually, reducing detergent and labor costs, energy and water consumption, and chemical overuse.
- One ½" soap connection with factory-installed supply line. Eight external chemical supply signals.
- Easy-access connection on the outside of the machine eliminates the need to open up the washer on routine visits.

## HANDLE MORE, WHILE USING LESS

- Maytag® TurboWash™ System specially designed spray baffles and tumble patterns provide more cleaning power while conserving water, cutting costs, and maximizing your profits.

## BUILT-TO-LAST™ FEATURES

- All Stainless Steel cabinet with industrial-strength door hinge, handle, and door lock.
- Cast-iron bearing housing with no bolts or welds.
- Pneumatic water valves and drain valves for reduced maintenance.
- Drains to the rear; rear drain connection.
- Drive system uses roller bearings and viton seals for maximum performance.
- Tilting available on select models. Tilting platform is pneumatic, up to a maximum 15° forward tilting angle.
- 3-year limited warranty—all parts.  
5-year limited warranty—shell, welded frame assembly, basket, shaft assembly, bearings and seals.

## EASY INSTALLATION

- Soft-mount, high-speed extractors feature a suspension system that allows washers to be installed in more locations and at a lower cost.

## EASY OPERATION

- Six-belt, self-tensioning drive system heating with Inverter Drive Technology for longer life.
- Up to 350 G's in final spin, reducing dry time.
- Pneumatic Steam Injection uses direct steam to maintain water temperature.
- One main switch with a standard emergency stop button and sensors on the door for safety.
- Five standard compartments for soap dispensing.
- Extra-large door opening for easy loading and unloading.
- Automatic Balance System with front-mounted balance switch.

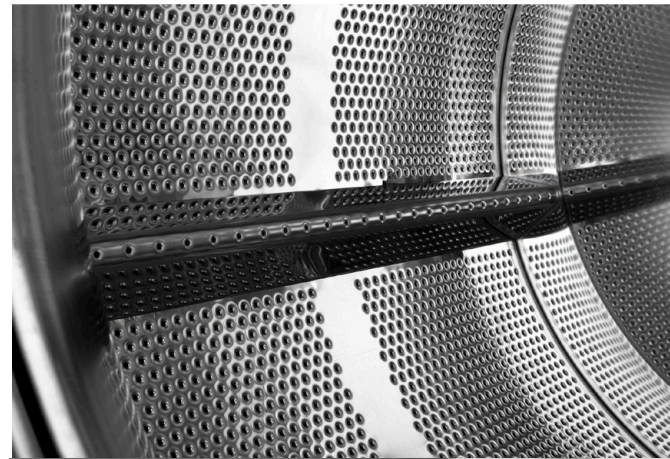

**MAYTAG® COMMERCIAL ENERGY ADVANTAGE™**  
**SOFT-MOUNT HIGH-SPEED WASHER/EXTRACTOR**  
**MICROPROCESSOR CONTROL**

WASHER SPECIFICATIONS					
MODEL	MFS180PA	MFS230PA	MFS230PT	MFS275PA	MFS275PT
<b>MOTOR</b>					
Inverter drive, variable speed	•	•	•	•	•
HP (kw)	11	15	15	18.5	18.5
Voltage/Phase/Hz					
Standard	208–240V 3 PH/50-60Hz	208–240V 3 PH/50-60Hz	208–240V 3 PH/50-60Hz	208–240V 3 PH/50-60Hz	208–240V 3 PH/50-60Hz
Optional	380–480V 3 PH/50-60Hz	380–480V 3 PH/50-60Hz	380–480V 3 PH/50-60Hz	380–480V 3 PH/50-60Hz	380–480V 3 PH/50-60Hz
<b>BREAKER SIZE — amps</b>					
Standard: 208–240V	60	75	75	100	100
Optional: 380–480V	30	50	50	60	60
<b>SPEED</b>					
Wash speed — rpm	36	35	35	34	34
Extract speed — maximum rpm	750	725	725	700	700
Extract speed — maximum g-force	350	350	350	350	350
<b>WATER INLET HOSE</b>					
Water inlet — BSP in. (mm)	3 x 1.5 (38)	3 x 1.5 (38)	3 x 1.5 (38)	3 x 1.5 (38)	3 x 1.5 (38)
Operating pressure — psi (bar)	14.5–116 (1–8)	14.5–116 (1–8)	14.5–116 (1–8)	14.5–116 (1–8)	14.5–116 (1–8)
Number of drain outlets	2	2	2	2	2
Drain size — in. (mm)	4 (103)	4 (103)	4 (103)	4 (103)	4 (103)
Steam connection — in. (mm)	1 (25.4)	1 (25.4)	1 (25.4)	1 (25.4)	1 (25.4)
Steam pressure — psi (bar)	44–116 (3–8)	44–116 (3–8)	44–116 (3–8)	44–116 (3–8)	44–116 (3–8)
<b>CAPACITY</b>					
Lbs. (kg) dry weight	180 (80)	230 (100)	230 (100)	275 (120)	275 (120)
Cylinder volume — cu. ft. (liters)	28.5 (807)	35.4 (1,003)	35.4 (1,003)	41.7 (1,181)	41.7 (1,181)
Cylinder diameter — in. (mm)	43.70 (1,110)	47.24 (1,200)	47.24 (1,200)	51.18 (1,300)	51.18 (1,300)
Cylinder depth — in. (mm)	33 (838)	33.85 (860)	33.85 (860)	34.25 (870)	34.25 (870)
<b>CABINET</b>					
Stainless Steel	•	•	•	•	•
<b>FORWARD TILTING — 15°</b>			•		•
<b>APPROXIMATE WEIGHT</b>					
Crated — lbs. (kg)	6,239 (2,830)	7,518 (3,410)	8,290 (3,760)	8,179 (3,710)	8,951 (4,060)
Uncrated — lbs. (kg)	5,820 (2,640)	6,989 (3,170)	7,761 (3,520)	7,672 (3,480)	8,444 (3,830)
<b>DIMENSIONS</b>					
A) Overall height — in. (mm)	79.13 (2,009)	76.77 (1,950)	86.41 (2,195)	81.88 (2,080)	91.73 (2,330)
B) Overall width — in. (mm)	60.23 (1,530)	70.86 (1,800)	73.22 (1,860)	73.03 (1,855)	73.22 (1,860)
C) Overall depth — in. (mm)	74.60 (1,895)	79.13 (2,009)	86.41 (2,195)	79.72 (2,025)	86.41 (2,195)
D) Door to floor — in. (mm)	34.37 (873)	35.83 (910)	46 (1,158)	34.45 (875)	44 (1,123)
Overall door opening — in. (mm)	20.87 (530)	20.87 (530)	20.87 (530)	25.59 (650)	25.59 (650)
<b>CRATED DIMENSIONS</b>					
Height — in. (mm)	86.61 (2,200)	92.33 (2,345)	97.63 (2,480)	92.12 (2,340)	97.63 (2,480)
Width — in. (mm)	66.53 (1,690)	73.42 (1,865)	80.31 (2,040)	78.73 (2,000)	80.31 (2,040)
Depth — in. (mm)	76.77 (1,950)	83.66 (2,125)	93.50 (2,375)	85.43 (2,170)	93.50 (2,375)

See specific instructions for proper installation. Because of continuous product improvement, Maytag reserves the right to change specifications without notice.

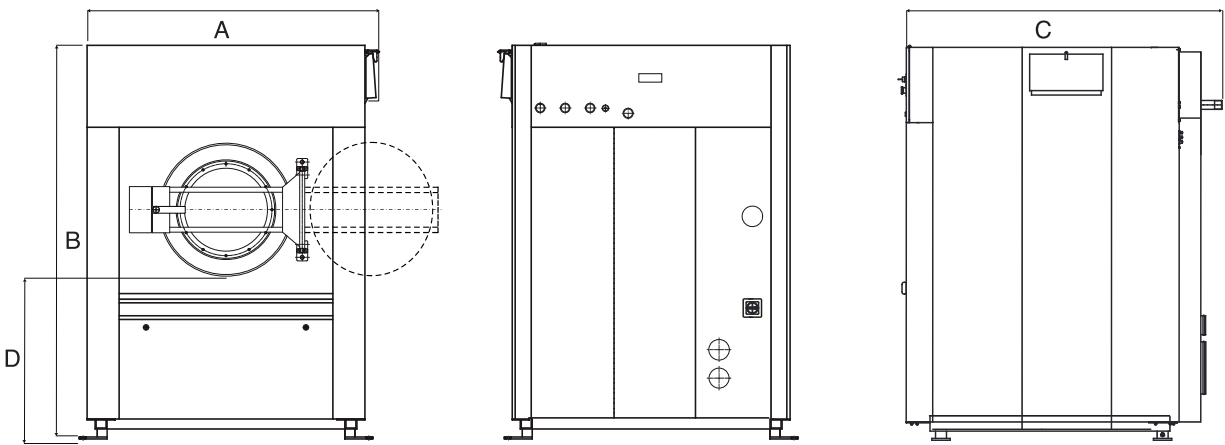



At Maytag, we believe durable goods should remain just that. That's why every Maytag® product is constructed of the highest-quality materials and with the utmost in precision craftsmanship. It's also why we stand behind our equipment with solid service and support from our professional Maytag laundry suppliers. Simply put, when you choose Maytag® products, you ensure your peace of mind.



**3 YEARS—ALL PARTS;  
5 YEARS—SHELL, WELDED FRAME ASSEMBLY,  
BASKET, SHAFT ASSEMBLY, BEARINGS AND SEALS.**

For a period from the date of original purchase through the time listed above, the designated parts that fail in normal commercial use will be repaired free of charge for the part itself, with the owner paying all other costs, including labor, transportation and customs duty. Chemical damage is excluded from all warranty coverage. See complete warranty for details.

Visit [maytagcommerciallaundry.com](http://maytagcommerciallaundry.com) or call 800-662-3587.

**OUR COMMITMENT TO DEPENDABLE QUALITY**



**WHAT'S INSIDE MATTERS™**