

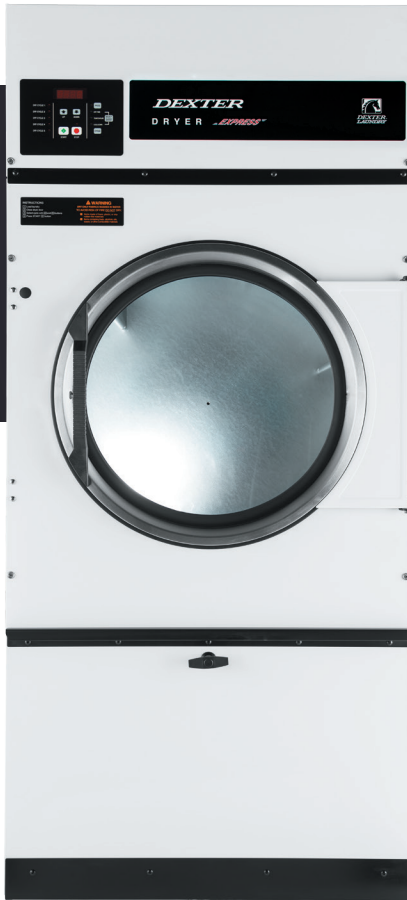

ON-PREMISE LAUNDRY T-30 EXPRESS DRYER



T-30 EXPRESS DRYER

Dexter On-Premise Dryer

On-premise laundry solutions you can depend on.

Dexter on-premise dryers are engineered to show up for work in even the harshest laundry environments. Featuring flexible controls and high quality materials, these fast and efficient dryers are designed to help you process laundry faster and more efficiently.

When your business depends on clean laundry, choosing the right equipment is an important decision. Our products will provide you the efficiency, flexibility, performance, and durability you need to be confident in your choice. With lifetime technical support and an industry leading 5 year limited warranty, you can be confident that we will stand behind every dryer you invest in.

Contact your Dexter Authorized Distributor today for more details.

EFFICIENT:

Perforated tumblers, balanced radial airflow, and the right amount of air recirculation provide maximum efficiency.

The anti-wrinkle feature offers an intermittent tumble to keep laundry wrinkle free.

DURABLE:

With heavy-duty bearings in a cast iron bearing housing and a fully welded and painted cabinet, Dexter dryers are built to last.

Using proven washer-style technology, welded steel spider assemblies support the tumbler from the rear and eliminate the need for front support rollers.

Formed in tumbler baffles are strong and stable while providing great tumbling action.

RELIABLE:

Our industry leading 5 year warranty covers the trunnion, bearings, and bearing housing.

A 3 year parts warranty covers the rest.

We stand behind every machine you invest in with lifetime technical support.

FLEXIBLE:

The reversible door option on all on-premise single dryers allows for a more ergonomic set up when needed.

Dexter on-premise dryer controls offer adjustable settings and five customizable cycles that provide the power and flexibility needed to fit any laundry.

INSTALLATION:

Vertical exhaust and venting come standard on every dryer for easy installation.

The exhaust cleanouts are easy to reach and allow for regular maintenance.

The hinged lower service door makes cleaning the lint screen quick and easy.

OPTIONS:

Available with stainless steel or galvanized tumblers and white or stainless steel panels.

Choose between gas models or electric models. Propane kits are available.

Dexter single dryers are available in 30lb, 50lb, 80lb, and 120lb capacities.

EMPLOYEE OWNED | MADE IN THE USA | SINCE 1894

DEXTER.COM

2211 WEST GRIMES AVENUE, FAIRFIELD, IOWA 52556 USA

1.800.524.2954

T-30 EXPRESS DRYER SPECIFICATIONS

ON-PREMISE LAUNDRY

Capacity:

Dry Weight Capacity	30 lb	(13.6 kg)
Cylinder Volume	11.3 cu ft	(320 L)

Speed:

Tumbler Speed	47 RPM	
Motor Size	0.5 hp	(0.38 kW)

Airflow:

60 Hz Model	830 cfm	(23.5 M3/min)
50 Hz Model	690 cfm	(19.5 M3/min)

Dimensions:

Cabinet Height	72 1/4"	(183.5 cm)
Cabinet Width	31 1/2"	(80 cm)
Cabinet Depth	41 3/4"	(106 cm)
Door Opening	22 5/8"	(57.5 cm)
Floor to Door Bottom	28 3/4"	(73 cm)
Cylinder Diameter	30"	(76.2 cm)
Cylinder Depth	27 1/2"	(69.9 cm)
Lint Screen Area	515 sq in	(3323 sq cm)

Weight:

Net Weight	454 lbs	(205.9 kg)
------------	---------	------------

Shipping Information:

Shipping Weight	499 lbs	(226.3 kg)
Shipping Height	77 1/4"	(196.2 cm)
Shipping Width	32 3/4"	(83.2 cm)
Shipping Depth	45 1/2"	(115.6 cm)

Gas Requirements (Gas Models Only):

Gas Supply Connection	1/2"	(12.7 mm)
Natural Gas Supply (Water Column)	5-10"	(12.7 - 25.4 cm)
LP Gas Supply (Water Column)	11 1/2 - 13 1/2"	(29.2 - 34.3 cm)

Gas Usage (Gas Models Only):

60Hz Model	90,000 BTU/hr	(26.4 kW)
50Hz Model	74,000 BTU/hr	(21.7 kW)

Electrical Requirements:

Gas Models:

Model	Volts / Hz / Phase / Wiring	Circuit Breaker / Running Amps / Wire Size
-10	120 / 60 / 1 / 2 wire + ground	15 amp / 9.6 amp / #12
-39	230 / 50 / 1 / 2 wire + ground	10 amp / 5.1 amp / 2.1 mm ²
-59	230 / 50 / 1 / 2 wire + ground	10 amp / 5.1 amp / 2.1 mm ²

Electric Models:

Model	kW / Volts / Hz / Phase / Wiring	Circuit Breaker / Running Amps / Wire Size
-71	24 / 208 / 60 / 3 / 4 wire + ground	90 amp / 85 amp / #2
-74	24 / 240 / 60 / 3 / 4 wire + ground	80 amp / 74 amp / #3
-77	20 / 208 / 60 / 1 / 3 wire + ground	125 amp / 120 amp / (1/0)
-78	20 / 240 / 60 / 1 / 3 wire + ground	110 amp / 105 amp / (1/0)
-79	24 / 400 / 50 / 3 / 4 wire + ground	50 amp / 45 amp / 3.5 mm ²

Installation Recommendations:

Minimum Clearance Between Machines	0"	(0 cm)
Minimum Clearance Behind Machines	18"	(45.7 cm)
Make-Up Air Required	1 sq ft	(929 sq cm)
Exhaust Size	8"	(20.3 cm)

Agency Approvals*

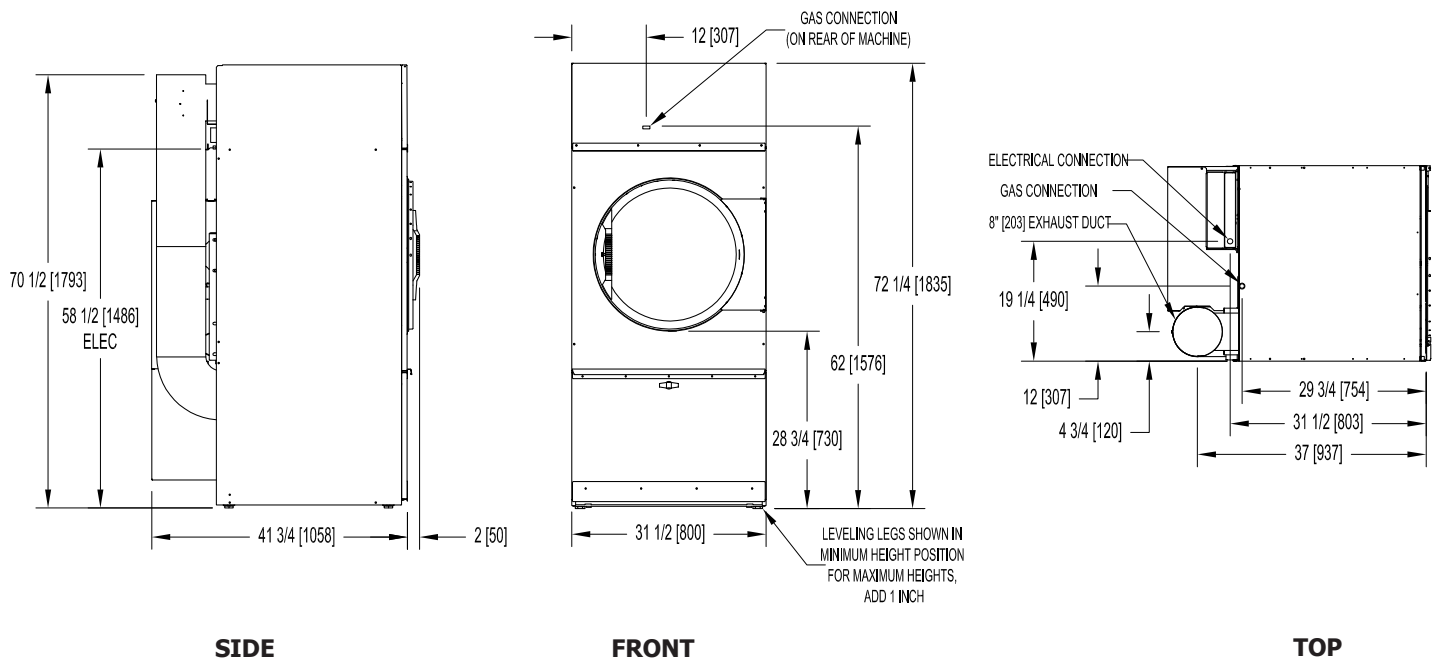

Due to continuous product improvements specifications are subject to change, please consult the installation manual for the most accurate information.
 *Agency approvals may vary depending on the machine configuration, consult Dexter Laundry or your Dexter Authorized Distributor for details.